

CONCRETE HOLDING RING - A.C. MAY BE JACK HAMMER CUT, NEATLY CONSTRUCTED & CENTERED ON MANHOLE.

STANDARD 24-INCH MANHOLE FRAME AND COVER PER AMERICAN PUBLIC WORKS ASSOCIATION - SOUTHERN CALIFORNIA CHAPTER STANDARD PLAN 630-2 USE 6" HIGH FRAME, COVER TO BE MARKED "SEWER," EXCEEDS H-20 WHEEL LOADING; MAXIMUM COVER WEIGHT 200 LBS.; MACHINE FRAME & COVER BEARING SURFACES FOR CLOSE, QUIET FIT

FINAL HEIGHT TO BE FLUSH WITH FINISH SURFACE. USE CLASS "A" CONCRETE.

PRECAST CONCRETE GRADE RINGS

24" X 48" PRECAST CONCRETE ECCENTRIC CONE

BITUMASTIC SEAL

SLOPE TO CHANNEL AT 1/4" PER FOOT STEEL TROWEL FINISH.

SECTION OF MANHOLE
SCALE : NONE

A

- INVERT OF ENTERING SEWER LINE TO MAIN / TRUNK (12" & >) SHALL BE ABOVE SPRING LINE OF MAIN / TRUNK.
- ALL SIDE PIPES INTO MANHOLE SHALL BE SMOOTH / FLUSH WITH MANHOLE INTERIOR SUFRACE.

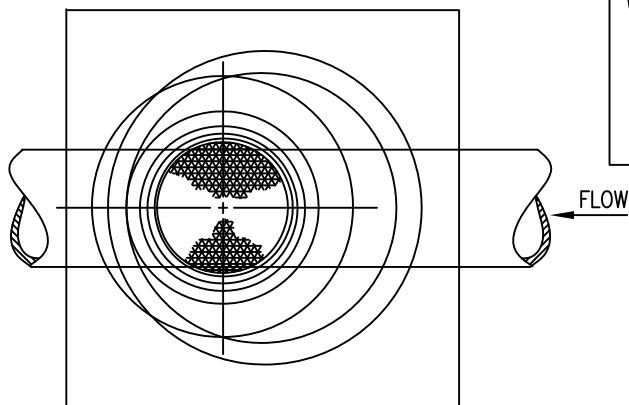

PLAN OF MANHOLE

SCALE NONE

(SHOWS FRAME & COVER ON DOWNSTREAM SIDE)

PRECAST CONCRETE MANHOLE PIPE SHALL CONFORM TO A.S.T.M. C-478. INSIDE SURFACE MUST BE SMOOTH & FREE OF SURFACE VOIDS. A MIN. THICKNESS OF 4 1/8" IF CENTRICALLY SPUN. A MIN OF 5" IF MECHANICALLY RODDED. (UNLESS OTHERWISE SPECIFIED IN THE SPECIAL PROVISIONS), T-LOCK MANHOLE PIPE WITH FACTORY INSTALLED PVC LINER ON 12" AND LARGER SEWERS.

INSTALL RAP-0 MANHOLE COVER CUSHION AROUND MANHOLE COVER BY MUNICIPAL SERVICES INC; 420 BOSTON TURNPIKE; SHREWSBURY MASS; 01545 OR APPROVED EQUAL.

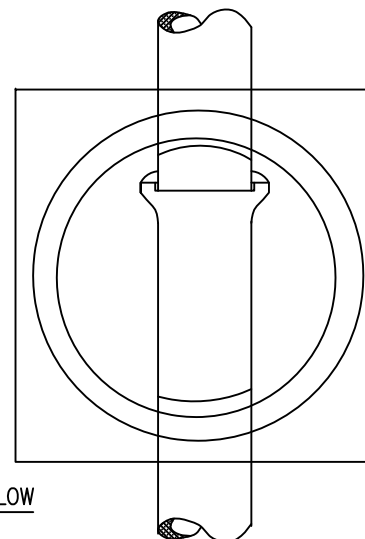

SECTIONAL PLAN

ONE WAY BASE

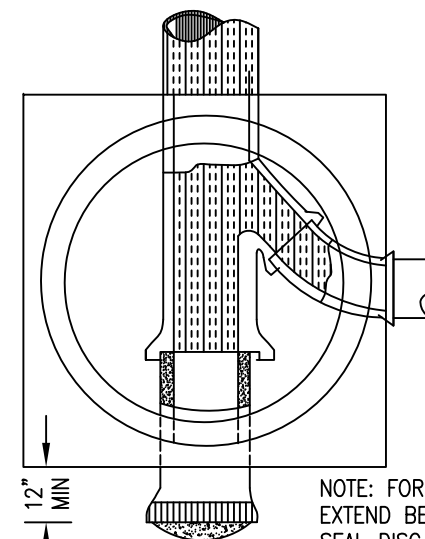

SECTIONAL PLAN

TWO WAY BASE

NOTE: FOR PIPE STUB OUT EXTEND BEYOND BASE & SEAL DISC & GROUT CAP.

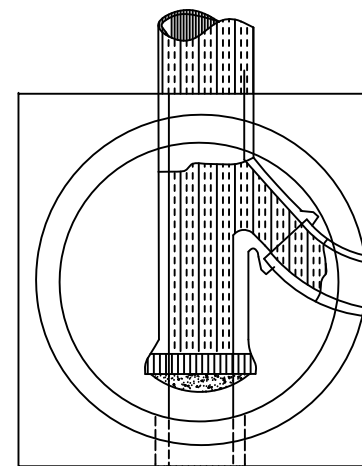

SECTIONAL PLAN

THREE WAY BASE

INCREASER FOR SMALLER LINE

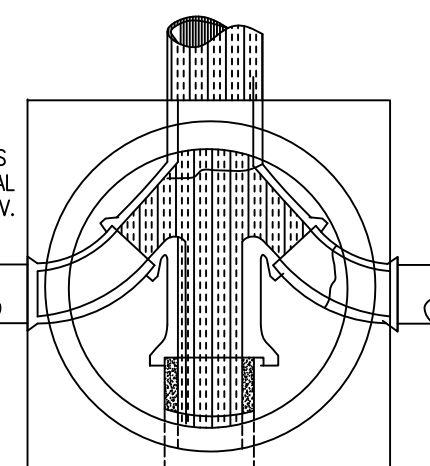

SECTIONAL PLAN

FOUR WAY BASE

SEE PLANS FOR LATERAL INVERT ELEV.

RICHARD G. SWEET R.C.E. 44,213 EXP. 6/30/07		DATE 11/22/04				City of Santa Maria	
REVISIONS		BY	APP			DATE	Standard Drawing
A	REVISION INDICATED	MK		8/06	DESCRIPTION: MANHOLE & DETAILS		STANDARD NUMBER
B	UTILITIES DEPARTMENT REVISIONS	CjP		6/08			SS-10C
C	UTILITIES DEPARTMENT REVISIONS	CjP		2/11			
DRAWN BY: R.L.B.		DATE DRAWN: 3/67		SCALE: NONE		SHEET 1 OF 1	