

**PLAN A**

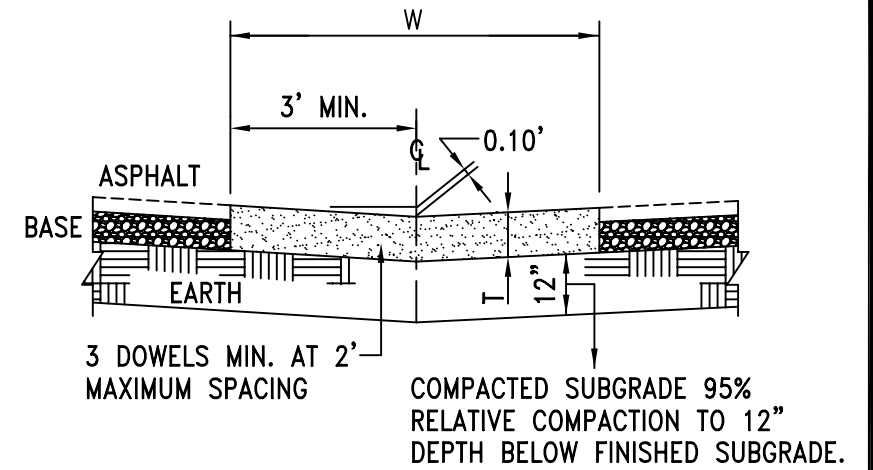

**SECTION B-B**

**GENERAL NOTES**

1. WORKMANSHIP AND MATERIALS SHALL COMPLY WITH CITY SPECIFICATION FOR MATERIALS AND THE CONSTRUCTION OF CONCRETE CURBS, GUTTERS, SIDEWALKS, DRIVEWAYS.
2. SUBGRADE COMPACTION - 95% AS MEASURED BY CALIFORNIA TEST METHOD 216 OR BY CALIBRATED NUCLEAR DENSITY INSTRUMENT.
3. SEE TABLE FOR VALUES OF GUTTER/SPANDREL THICKNESS (T) AND WIDTH (W) AND CURB RETURN RADIUS (R).

STREET DESIGNATION	T (MIN.)	W (MIN.)	R (MIN.)
PRIMARY ARTERIAL	8"	12'	35'
SECONDARY ARTERIAL	8"	12'	35'
COLLECTOR	6"	8'	27'
LOCAL	6"	6'	27'
MINOR	6"	6'	27'
DRIVEWAY	6"	6'	15'

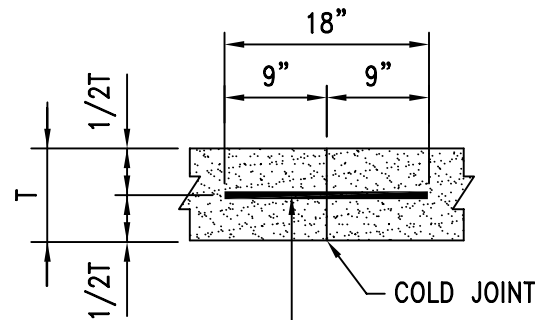

5/8" DIA. SMOOTH SOLID STEEL DOWEL 18" LONG (ONE END WRAPPED WITH 6 MIL. VISQUEEN)

**DETAIL C**

RICHARD G. SWEET R.C.E. 44,213 EXP. 6/30/07 REVISIONS BY APP DATE		3/17/05 DATE	<b>City of Santa Maria</b> <b>Standard Drawing</b>	
DRAWN BY: J.H.			DATE DRAWN: 10/02	
SCALE: NONE			SHEET 2 OF 2	
DESCRIPTION:		<b>CROSS GUTTER AND SPANDREL (ALT. R/W LINE)</b>		
STANDARD NUMBER		<b>RD-19</b>		